

INVESTIGATION OF ION SOURCES AND INJECTOR USED IN RFQ ACCELERATOR*

Yu Jinxiang, Chen Jiaer, Ren Xiaotang, Song Zhizhong, Wang Zhongyi,
Zhang Zhengfang, Lu Yuanrong, Li Weiguo and Fang Jiaxun
Institute of heavy ion physics, Peking University, Beijing 100871, PR China

Abstract

Two kinds of PIG ion source with permanent magnet used for RFQ are developed, mA of O^+ and O^- beams can be extracted from them and O^- and O^+ ion ratio is 70-80%, respectively. The injector built for RFQ consists of ion sources, einzel lenses, steerer and funnel magnet et al. and the beam lines of the injector are calculated by LEADS program. And its beam transmission is of about 70-80%. It has been used in our 300kV and 1 MV integral sprit ring RFQ successively. The experiments of O^+ and O^- ion beam accelerated simultaneously were taken, several hundred μ A of O^+ and O^- ion beam accelerated by both RFQ was measured and the total current of O^+ and O^- ion beam accelerated simultaneously is far lager than that of O^+ or O^- ion beam accelerated singly.

1. INTRODUCTION

In recent years radio frequency quadrupole (RFQ) accelerators have been proposed to use for ion implanter used in SIMOX, boron neutron capture therapy (BNCT) and accelerator-driven transmutation technologies (ADTT) etc., owing to its advantages of high beam intensity and high beam transmission ratio. In the uses as mentioned above, a kind of charged particle is only accelerated by a half period of radio frequency field in the RFQ usually, and the beam intensity accelerated is of about 100 mA for proton beam because of limit of space charge effect. But in the application fields of ADTT and

SIMOX several hundreds mA of hydrogen and oxygen ion beam is offered by RFQ usually. In order to get such beam intensity R. A. Jameson (LANL) has used two RFQs with 125mA/2.5MeV as injector for the ADTT project, which results in rise of the project cost obviously¹. According to the fact that a half period of radio frequency field is only utilized in RFQ. If negative and positive ions with the same q/m are accelerated in RFQ simultaneously, the ultimate ability of RFQs' beam load can be increased one time in principle. In 1993 we proposed an idea of simultaneous acceleration of negative and positive ions with the same q/m, after that we have developed two kinds of PIG ion source with permanent magnet used for producing O^+ and O^- ions. And based them an injector was built for our integral sprit ring RFQ (ISR-RFQ). The experimental research on simultaneous acceleration of O^+ and O^- ions was taken in a 300 kV and 1MV ISR-RFQ successively^{2,3}.

2. ION SOURCES

According to the requirements of R & D of our ISR-RFQ, we have improved two kinds of PIG ion source with permanent magnet used for producing negative and positive ions, especially for O^+ and O^- ions. For both sources mA of O^+ and O^- beams can be extracted, and O^- and O^+ ion ratio is 70-80%, respectively. One of them is a multi-purpose pocket end extraction PIG ion source, which can produce varied ions including metal and negative ions (Fig.1)⁴. And in this source total current of negative oxygen ions is 2-3 times of that of

Supported by NFSC

positive oxygen ions normally. Therefore it is used for producing O^- ions, and in which negative ion formation occurred both on the cathode surface and in the discharge volume, and mainly on the cathode surface. So cathode material should adopt those with as low as work function, and multi-crystal LaB_6 cathodes with work function 2.7eV are verified the best one for producing O^- ions in our experiments up to now. Recent years in order to increase O^- ion current, we have also researched dependence of O^- ion current on magnet field, and found that as the SmCo magnet size was changed from $\phi 2 \times 1.8$ to $\phi 3 \times 3$ cm, O^- ion current can increase 100% under fixed other experimental condition. And now the source with a $\phi 3 \times 3$ cm SmCo magnet at 80mA discharge current, 10kV extraction voltage and 3mm cathode hole, about 2mA O^- and F^- ion beam can be extracted. The dependence of extracted total current I_t on extraction voltage V_{ex} can be expressed by $I_t = kV_{ex}^{1.4-1.6}$, in which k is constant.

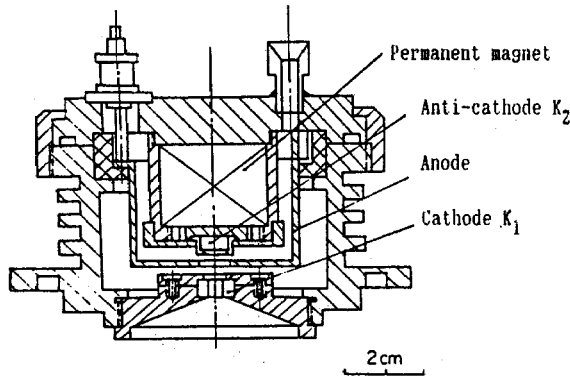

Fig.1 A pocket end extraction PIG ion source

The another one is side extraction PIG ion source with SmCo permanent magnet, which we have developed in 1980 years, it is now used to produce N^+ and O^+ ion current for our ISR-RFQ (Fig.2) ⁵. And in 1995 we designed a new one with NdFeB permanent magnet, in which the magnet mirror ratio is increased and the plate electrode extraction system is adopted. With these arrangements the extracted atom ion ratio is raised to 80-90%, and mA of N^+ and O^+ ion beam can be extracted at 80 mA discharge current and 20 kV extraction voltage.

Up to now the both sources have been well used in our ISR-RFQ for several years, they can operate in CW or pulse mode, and in pulse mode pulse width 1 ms,

repeated rate 166 Hz are the same as those of RF transmitter driven RFQ.

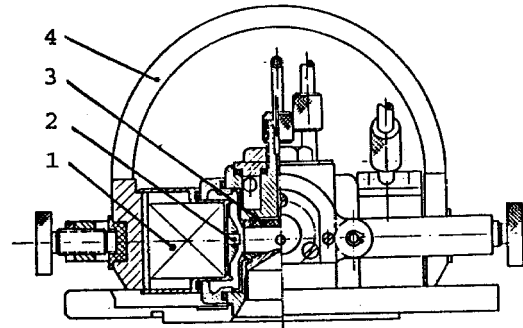

Fig.2 A side extraction PIG ion source, 1. SmCo magnet, 2. cathode, 3. anode, 4. magnetic yoke

3. INJECTOR

The injector is shown as Fig.3, it is located at before the ISR-RFQ. Two permanent magnet PIG ion sources extracted O^+ and O^- ion beam located at $\pm 45^\circ$ with the RFQ beam axis. Extracted O^+ and O^- beam are focused by einzel lens EL1 and EL2, respectively. In order to overcome additional deflect of O^+ beam caused by fringing magnet field in the extraction region of the positive ion source (IS+), a electrostatic steerer is led in the beam line after EL1. And then the both beams are deflected to the same beam axes by funnel magnet FM with curve radius 20 cm. The centered beams are focused to converging beams by einzel lens EL3, and pass through 1.5 cm diaphragm (GL) injected it to 26 MHz ISR-RFQ. The beam intensity of O^+ and O^- at the entrance and exit of the RFQ is measured by Faraday cup FC1 and FC2, respectively. The energy spectrum of O^+ and O^- beam accelerated by RFQ is given by a R60 cm / 90 ° analyzing magnet (AM). For increasing transmission efficiency of the injector, the cross section size of the beam transport elements was increased suitably, and the beam line of the injector was decreased as possible. Now the diameter of three-cylinder einzel lens EL_{1-3} is 5 cm, and the effective gap of funnel magnet FM is 3.2 cm, and the beam line length for O^+ and O^- is 120 cm only. Beam envelope of the injector was simulated by LEADS program, and the simulation results are coincidence with beam experimental results. 0.5-1

mA of O^+ and O^- ion beam can be got at the entrance of the ISR-RFQ. The experiments showed that the beam transmission for the injector system is of about 70-80%.

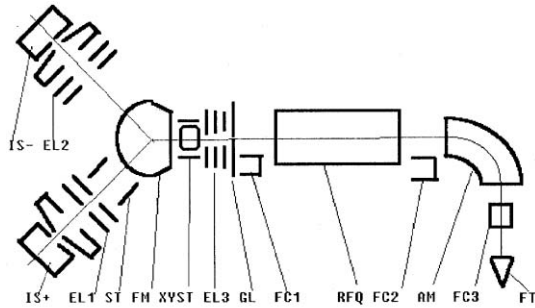

Fig.3. Layout of the injector and ISR-RFQ for simultaneous accelerating of negative and positive ions with equal q/m

IS⁻--negative ion source, IS⁺-- positive ion source, EL1-3-- einzel lens, ST--steerer, FM--funnel magnet, XYST-- x-y steerer, GL--diaphragm, RFQ--26 MHz/300 kV or 1MV ISR-RFQ, AM-- analyzing magnet, FT--fast target

4. RESULTS

Since 1996 we have tested single and simultaneous acceleration of O^+ and O^- beam in 300 kV and 1 MV ISR- RFQ successively. At RF driven power 30 kw and RFQ cavity vacuum $(6-9) \times 10^{-6}$ Pa, 300-600 μ A of O^+ and O^- ion accelerated current were measured at the exit of both RFQ accelerators, and the beam transmission is of about 80%. And it is observed that the total current of simultaneous acceleration of O^+ and O^- beam is far larger than that of single acceleration of O^+ or O^- beam. And

the sum of O^+ and O^- beam current at simultaneous acceleration is less than sum of O^+ and O^- ions at single acceleration. It is the reason that the focussing voltage of EL3 could not take optimum for both O^+ and O^- beam at simultaneous acceleration, owing the difference of the emittance of both sources. Even though utilization efficiency of RFQ accelerator was raised at simultaneous acceleration of O^+ and O^- beam.

5. SUMMARY

The idea of simultaneous acceleration of negative and positive ions with the same q/m in RFQ was verified by experiments in our ISR-RFQ, with this method the ability of beam load of RFQ can be raised. And different elements with the same q/m can be accelerated in RFQ and implanted in wafer simultaneously, it will be useful for material science research.

REFERENCES

1. Jameson R.A., Lawrence G.P et al., Nucl. Instrum. Methods, 474 (1992).
2. Yu Jinxiang, Chen Jiaer et al., Trends in Nuclear Physics, 13(2), 34 (1996) in Chinese.
3. Yu Jinxiang, Chen Jiaer et al., Atomic Energy Science and Technology, 35(1), 34(2001) in Chinese.
4. Jinxiang Yu, Xiaotang Ren, and Zhizhong Song, Rev. Sci. Instrum. 67(3), 1375 (1996).
5. Z. Song et al., Vacuum 36, 897 (1986)